

# Chegg

## Q&A Authoring Guidelines

October 2024

# Table of Contents

- 01 Your Journey
- 02 Practice Site
- 03 Check My Structure (CMS)
- 04 Your Dashboard
- 05 Question Window
- 06 How To Skip Questions?
- 07 How To Attempt?
- 08 Solution Window
- 09 Chegg “Honor Code”
- 10 Quality Review
- 11 Other Points To Keep In Mind
- 12 Practices To Avoid
- 13 Payments & How To Contact Us?

# Your Journey

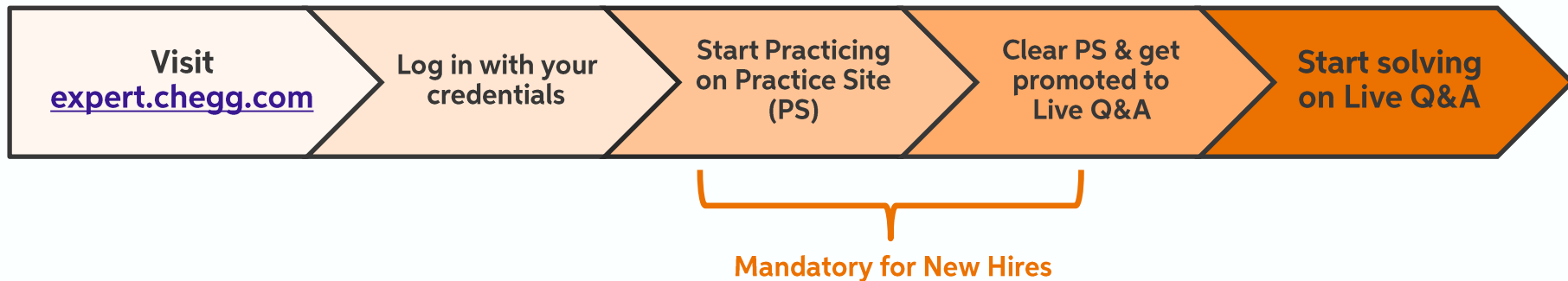

Your Chegg Q&A journey starts the day you get your Q&A authoring privileges.

**Practice Site (PS):** To enhance the authoring experience for newly hired experts, we have introduced the Practice Site on the Q&A dashboard.

- The Practice Site feature is mandatory only for newly hired experts. There are no changes in the Q&A dashboard for existing experts.
- You will be **paid** for all the valid solutions submitted in passed attempt on the Practice Site.

# Practice Site

## Promotion Criteria for Live Q&A

Particulars	Criteria
Solution Count	3
Average QC score	$\geq 4.5$
Skip limit (per attempt)	100

### Follow these steps to start your journey as an expert:

1. Go to [expert.chegg.com](https://expert.chegg.com).
2. Sign in with your credentials.
3. You will be redirected to the home page.
4. Go through all the **training videos** and finish the mandatory training.
5. Click on "Start practicing".
6. Surface through the questions, start typing your solution, and provide a step-by-step detailed explanation. Please note that you can **skip a maximum of 100 questions per attempt**. If you try to skip more than that, your attempt will be marked as unsuccessful.
7. Once you fulfill the above-mentioned criteria i.e., submitting at least **3 solutions with an Avg QC score of  $\geq 4.5$** , you'll receive access to the Live Q&A within 4 days.
8. You will be **paid** for all the valid solutions submitted in passed attempts on the Practice Site. Payments will be credited by the 25th of every month when your QC score for the same will be generated last month between the 1st-31st.
9. No payment will be made for questions solved in the failed attempt(s).

# Check My Structure (CMS)

**Check My Structure** serves as a 24/7 guide to help author better-structured solutions.

The 'Check My Structure' feature on the authoring platform can be used by clicking the '**Check Structure**' button; it is always available while you create your solution.

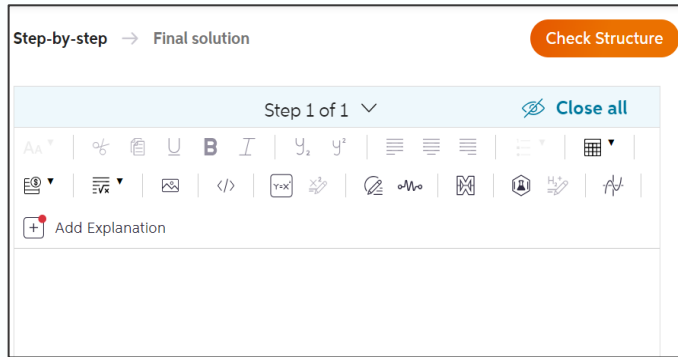

The screenshot shows the authoring platform interface. At the top left, it says "Step-by-step → Final solution". On the right, there is an orange button labeled "Check Structure". Below this is a toolbar with various editing tools like bold, italic, underline, and a "Close all" button. At the bottom left, there is an "Add Explanation" button.

When you click the '**Submit your solution**' button, a pop-up with structuring recommendations will also appear as shown below:



The screenshot shows a pop-up window titled "Check my structure". It contains a table with the following requirements and points:

Requirement	Points	Mark as Not Applicable
You have 37 of 60 total points for a score of 62%. Please ensure your score is at least 75% to submit your answer.		
1. Steps in solution. Students prioritize answers with <b>two or more steps</b> over single-step answers.	10/10 points	
2. Required editor tools. Receive 5 points for each usage of a math tool or other editing tools.	5/10 points	
3. Words per step. We recommend <b>min 10 words per step</b> for comprehensive learning.	2/10 points	
4. Explanations. Steps with <b>explanations</b> help make learning easier.	10/10 points	
5. No images allowed. Images of content that can be created in Expert 2.0 are not permitted.	10/10 points	
6. Final answer word count. Final answers with <b>min 10 words</b> increase solution clarity.	0/10 points	

At the bottom of the pop-up, there is an orange button labeled "Improve and use editor tools".

**Note: You must achieve at least a 75% Check My Structure (CMS) score.**

# Your Live Q&A Dashboard

The dashboard is titled "Your Live Q&A Dashboard" and features the Chegg logo in the top left. The navigation bar includes "Home" and "My Past Activities" with a dropdown arrow. On the right, there are links for "Guide Me", "Notifications", and a user profile icon.

The main content area is divided into several sections:

- Header:** "What would you like to do today?" with a callout box: "Visit your previously submitted solution/s." pointing to the "My Past Activities" dropdown.
- Q&A Authoring Card:** Features a document icon, the title "Q&A Authoring", and sub-headers "NA Pricing" and "200 Q Limit". The text reads: "Students love reading clear, step-by-step solutions. Author well-explained solutions using our in-built editor." Below this, it shows "CF Score: N/A" and "QC Score: 5.00" with an information icon. A "Start solving" button is at the bottom. Callouts include: "This section shows your performance stats." pointing to the "My Stats" section, "Improve your Chegg rating to increase your authoring price multiplier and authoring limit." pointing to the "QC Score: 5.00", and "Visit the question window" pointing to the "Start solving" button.
- My Stats:** A section titled "My Stats" with a "Today" dropdown. It contains a table for "Q&A Authoring" performance:

Q&A Authoring	
CF Score	N/A
Solved	0
Skipped	0

Below the table is a blue information box: "Ensure you follow the Q&A Authoring Guidelines to maintain a CF Score of 80% or more. For any help, please visit our support page." with a close icon.

- User Guidelines:** A section titled "User Guidelines" with a "Q&A Authoring" button.
- Contact us:** A section titled "Contact us" with the text "Reach out for any support or queries." and a right-pointing arrow. A red question mark icon is located below this section.
- Support ticket unresolved?:** A section with a dropdown arrow and an information icon.

The bottom section is titled "Frequently Asked Questions" and has two tabs: "Overall" and "Q&A Authoring". It lists two questions:

- "My question got skipped automatically. How can I get the same question again?"
- "What happens if my account gets revoked?"

# Question Window

Click on **Start solving** to take you to the question

You get 10 minutes to decide if you want to solve or skip/exit the question

**Student question** Time Left : 00:09:48

Suppose you plan to build a portfolio with Call and Put options in amounts of each that you must determine, giving the following payment pattern:

**Note:** If you do not decide in the allocated **10 minutes**, the question gets skipped automatically and a new question will appear on your screen.

Click here to skip the question and move to the next one.

Click here to start solving the question.

Click here to exit.

Skip question Start Solving Exit

Show Transcribed Text

# How to Skip Questions?

You can skip a question whenever you want, provided you select the correct skip reason. You can choose the reason from the list below:

- **"I can solve, but the question..."** - Choose whether the question is difficult, lengthy, has multiple subparts, or has multiple questions.
- **"I cannot solve this question, because..."** - Choose whether the question is blurred, incomplete, requires external tools, does not belong to your subject, or you do not know the solution.
- **"This question violates authoring guidelines."** - Choose whether the question belongs to an exam/ test/ quiz, has a copyright/external URL, requires lab work, is spam, or has points/ marks/ grades.

### Why are you skipping this question?

I can solve, but the question:

I cannot solve this question, because:

This question violates authoring guidelines:



# How to attempt?

**Multiple Choice Questions (MCQs):** Provide the correct option, and a detailed explanation of why that option is correct and why the remaining aren't.  
Example:

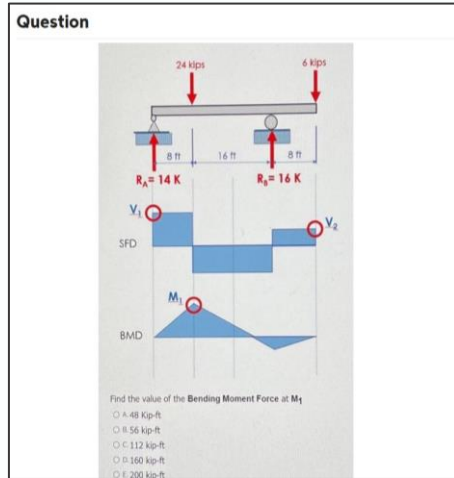

**Solution approach:** A detailed explanation for each option, i.e., which option is correct, why, and the reasoning for the incorrect options.

**Multiple Questions:** Solve all the questions, **unless** the student has asked for a specific question to be solved.  
Example:

## Questions

- 1.) What is respiratory system?
- 2.) How do plants make food?
- 3.) Explain diversity in living organisms.
- 4.) What are communicable diseases and how to control them?

**Solution approach:** Solve all the questions (as the student didn't specify which one among the 4 needs to be solved).

# How to attempt?

**Questions with sub-parts:** Solve all parts of multiple sub-part questions unless the student has specified to solve only certain sub-part/s. Example:

Write the MATLAB CODES for questions (1-5) and show the output, this problem must be solved in matlab. Only solve in MATLAB AND PROVIDE THE OUTPUT SCREENSHOTS

A digital communication link carries binary-coded words representing samples of an input signal-

$$x_d(t) = \cos(2000\pi t) + 3\cos(5000\pi t) + 5\cos(9000\pi t)$$

The link is operated at 24,000bits/second and each input signal is quantized into 4096 different voltage levels.

- 1) What is the Nyquist rate for this signal?
- 2) What is the sampling rate, sampling interval, folding frequency for this signal?
- 3) What is the discrete-time signal obtained after sampling? (Find out the simplest form)
- 4) Determine whether the discrete signal is periodic or not. Compute the fundamental period if the signal is periodic.
- 5) What is the analog signal  $y_a(t)$  that we can reconstruct from the samples if we use ideal interpolation?

**Solution approach:** Solve all the sub-parts of the question. Add the solution of all the sub-parts in your Final Solution section.

**Questions in non-English language:** Solve only when you know the language. If you are unable to understand or translate the language, skip the question under "**I can't solve this question because: >Question is incomplete**" and ask the student to upload the question in English.

Example:

二, 用“的”, “得”或“地”填空:

1. 我朋友把我房间扫 ( ) 真干净。
2. 桌子上 ( ) 书不是我的书。
3. 她绣花绣 ( ) 非常漂亮。
4. 她开心 ( ) 说笑。
5. 清清 ( ) 河水不断的流着。

**Solution approach:** Solve only when you know the language and submit the solution in English Language only.

# Solution Window

- Clicking the **'Start Solving'** button on Question Window takes you to the Solution Window. On the left, you will see the question; and on the right, you will see the Solution Window.
- You have exactly 120 minutes to solve the question. If you need an extra 30 minutes, take advantage of the bonus time that will be offered at 110 minutes into the 120-minute session. If the whole solution is not provided within the allocated 120 minutes, the question gets skipped immediately. Compensation is not provided for such solutions.
- In case you encounter difficulty while solving a question, you always have the option to skip it and proceed further.

The screenshot displays the Chegg Solution Window interface. On the left, under the heading "Student question", a problem is presented: "We are evaluating a project that costs \$799,000, has a life of 7 years, and has no salvage value. Assume that depreciation is straight-line to zero over the life of the project. Sales are projected at 158,000 units per year. Price per unit is \$42, variable cost per unit is \$24, and fixed costs are \$809,387 per year. The tax rate is 21 percent, and we require a return of 17 percent on this project." Below the text are eight numbered questions: 1. Calculate the accounting break-even point. 2. What is the degree of operating leverage at the accounting break-even point? 3. Calculate the base-case cash flow. 4. Calculate the NPV. 5. What is the sensitivity of NPV to changes in the quantity sold? 6. What your answer tells you about a 500-unit decrease in the quantity sold? 7. What is the sensitivity of OCF to changes in the variable cost figure? 8. How much will OCF change if variable costs decrease by \$1?

At the top right of the question area, a timer shows "Time Left: 01:59:18". To the right of the question, there are navigation options: "Tag the question" (selected), "Step-by-step", and "Final solution". Below these are "Subject" (Finance) and "Sub-subject" (Search And Select) dropdown menus. At the bottom left, there are buttons for "Skip question" and "Exit". At the bottom right, there are buttons for "Back", "Next", and "Submit your solution" (with a question mark icon).

The solution flow is divided into **three main steps**:-

## 1. Tagging

- Select the sub-subject and topic
- Click "Next" for step-by-step solution
- Make sure to tag the question correctly

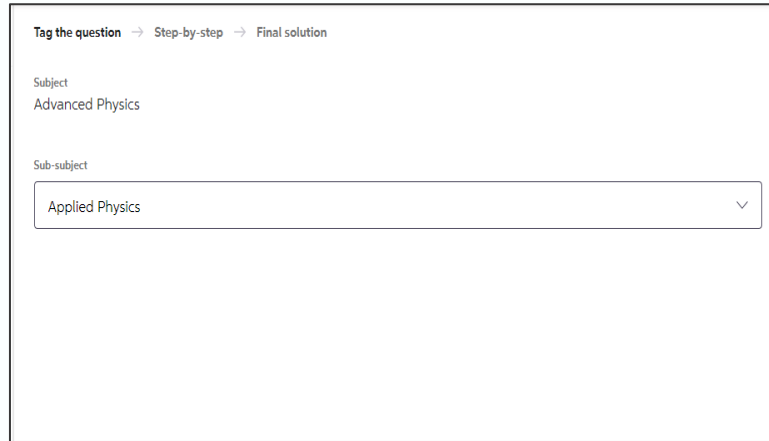

The screenshot shows the tagging interface. At the top, there are navigation links: "Tag the question" (selected), "Step-by-step", and "Final solution". Below this, there are two sections: "Subject" with the text "Advanced Physics" and "Sub-subject" with a dropdown menu showing "Applied Physics".

## 2. Step-by-Step

- Every solution begins with a default step and allows you to add further steps by clicking "Add another step" at the editor's bottom.
- Promote comprehensive student learning through step-by-step solutions.
- Enhance quality by including explanations within the steps as required.

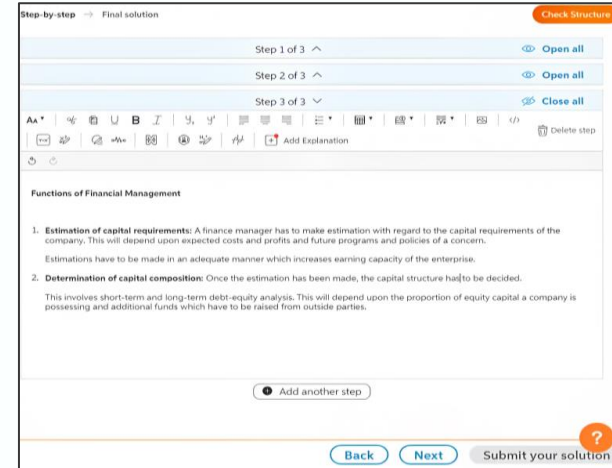

The screenshot shows the step-by-step solution editor. At the top, there are navigation links: "Step-by-step" (selected) and "Final solution". There is a "Check Structure" button in the top right corner. Below this, there are three steps: "Step 1 of 3", "Step 2 of 3", and "Step 3 of 3" (selected). Each step has an "Open all" button. Below the steps, there is a rich text editor with a toolbar containing various formatting options. The text in the editor reads: "Functions of Financial Management". Below the text, there are two numbered list items: "1. Estimation of capital requirements: A finance manager has to make estimation with regard to the capital requirements of the company. This will depend upon expected costs and profits and future programs and policies of a concern. Estimations have to be made in an adequate manner which increases earning capacity of the enterprise." and "2. Determination of capital composition: Once the estimation has been made, the capital structure had to be decided. This involves short-term and long-term debt-equity analysis. This will depend upon the proportion of equity capital a company is possessing and additional funds which have to be raised from outside parties." At the bottom of the editor, there is an "Add another step" button. At the very bottom, there are three buttons: "Back", "Next", and "Submit your solution".

### 3. Final Solution

After completing the step-by-step solution, add “**Final Solution**”.

- **Final Solution:** Provide a concise and clear summary of the solution in easy-to-understand language.
- **Referencing Content:** If the Final Solution includes content that's already in the steps (e.g., tables or journal entries), then a simple sentence is enough, pointing to the relevant step.
- **Preview and Submission:** Preview the completed solution by clicking "Preview your solution" to see how it will appear to students. Once finalized, submit the solution by clicking "Submit your solution".

The screenshot shows the 'Final Answer' editor in Chegg. At the top, there are navigation links for 'Step-by-step' and 'Final solution', and a 'Check Structure' button. The editor has a rich text toolbar with various icons for text formatting, alignment, and insertion. Below the toolbar, there are undo and redo buttons. The main text area contains the following instructions:

After completing the step-by-step solution, add “**Final Solution**”.

- **Final Solution:** Provide a concise and clear summary of the solution in easy-to-understand language.
- **Referencing Content:** If the Final Answer includes content that's already in the steps (e.g., tables or journal entries), then a simple sentence is enough, pointing to the relevant step.
- **Preview and Submission:** Preview the completed solution by clicking "Preview your answer" to see how it will appear to students. Once finalized, submit the solution by clicking "Submit your answer".

At the bottom of the editor, there is a 'Preview your solution' button. Below the editor, there are three navigation buttons: 'Back', 'Next', and 'Submit your solution'. A question mark icon is visible in the bottom right corner of the editor area.

# Solution Formatting/Alignment

## Wrong Formatting/Alignment

Step 2/3

The term "linear moment" is not represented with a variable and equations are written in the same line.

Before collision total linear momentum in the direction of ball =  $7.9 \times 8.3 = 65.57 \text{ kgm/s}$

After collision total linear momentum in the direction of ball  
=  $7.9 \times 6.5 \cos 1.70^\circ + 0.826 \times v \times \cos 18.5^\circ \text{ kgm/s}$

Where v is velocity of balling pin.

Step 3/3

The format of units should be in the equation editor instead of the text.



## Correct Formatting/Alignment

Calculate the total linear momentum in the direction of ball before collision.

$P_1 = 7.9 \times 8.3$   
 $= 65.57 \text{ kg} \cdot \text{m/s}$

The term "linear moment" is represented with a variable and units are also written in the proper format.



Write the equation for total linear momentum in the direction of ball after collision.

$P_2 = (7.9 \times 6.5 \cos 1.7^\circ) + (0.826 \times v \times \cos 18.5^\circ)$   
 $= 51.32739 + 0.7833v$

The equation is clearly written and simplified

# Chegg “Honor Code”

Experts help students with the toughest questions while maintaining the highest standards in academic work. In doing so, Experts **must not** participate in aiding **academic dishonesty**.

As an Expert, you must adhere to our “**Honor Code**” to ensure you can continue working with us. **Any violation of our Honor Code would result in revocation of your Expert privileges.**

*Note: Experts should not subscribe to a student account. If found, both student and expert accounts will be terminated, and any balance payment or student subscription amount will be forfeited.*

# Honor Code: Dealing with Examination/Copyrighted Questions

**Do not solve** questions with logos/watermarks of institutions, e.g., “Ryerson University”, “Exams Institute”, “Div. Ched”, “ACS”, or “Sapling Learning”, as these are examination / copyrighted questions.

You must skip these under the **“This question violates authoring guidelines: > Copyright/External URL”** reason.

The concept of present value relates to the idea that

- The discount rate is always higher when you invest now than in the future
- The discount rate is always higher when you invest in the future than
- The money you have now is worth less today than an identical amount you would receive in the future
- The money you have now is worth more today than an identical amount you would receive in the future

The formula for calculating future value (FV) is

- $FV = PV / (1+r)^n$
- $FV = PV / (1+r) * n$
- $FV = PV \times (1+r)^n$
- $FV = PV \times (1+r) * n$

**X**

Find the value of  $I_1$ ,  $I_2$  and  $I_3$ .

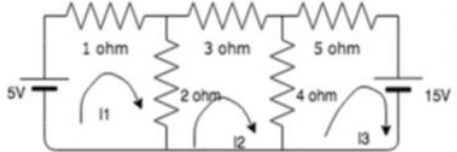

- a) -0.566A, 1.29A, -1.91A
- b) -1.29A, -0.566A, 1.91A
- c) 1.29A, -0.566A, -1.91A
- d) 1.91A, 0.566A, 1.29A

© 2000-2019 John Wiley & Sons, Inc. All Rights Reserved. A Division of

**X**



# Honor Code: Dealing with

## – Examination/Test Questions, Activity-Based Questions

**Do not solve** questions that include terms such as "Final Exam," "Test," "Exam," or "Quiz" without specific dates or dates related to current and future years. If you come across such questions:

- Skip them under **"This question violates authoring guidelines: > Exam/Test/Quiz"** as we do not support any kind of Cheating/Academic dishonesty.

**Do not solve** questions that require you to perform an activity or experiment to arrive at the final solution.

- Skip them under **"This question violates authoring guidelines: > Requires Lab Work"**

58. The polymer shown is approved for the FDA for intravenous use because the hydrolyzation (biodegradation) under normal physiological conditions results in the formation of two monomers that are easily handled by the body. It is an example of a Claisen polymer. Which monomers would be formed on hydrolysis of this polymer?

(A) HOCH2CH(OH)CH2OH and HOOCCH(OH)CH2OH  
(B) HOCH2CH(OH)CH2OH and HOCH2CH(OH)CH2OH  
(C) HOCH2CH(OH)CH2OH and HOCH2CH(OH)CH2OH  
(D) HOCH2CH(OH)CH2OH and HOCH2CH(OH)CH2OH

59. Which is most basic?

(A) C1=CN=CN=C1 (B) C1=CC=C(N)C=C1  
(C) C1=CN=CN=C1 (D) C1=CC=CC=C1

**X Exam Question**

Module 6 Virtual Lab: Functional Group Scavenger Hunt

Name: \_\_\_\_\_

Instructions: In this activity you'll get practice identifying and drawing aldehydes, ketones, and alcohols. Remember if you'd like to visualize things you can use [www.molview.org](http://www.molview.org). Fill in each row of the table with the missing pieces of information.

Condensed Formula	Skeletal Structure	Functional Group(s)	Compound Type (alcohol, aldehyde, or ketone)	Alcohol Class (Primary, Secondary, or Tertiary - if not an alcohol leave blank)
<chem>CH3CH2OH</chem>				
<chem>CH3O</chem>				
<chem>CH3CHO</chem>				

**X Activity Based Question**

**Note:** Questions belonging to any previous year's examination, quiz, or test are not spammed and can be attempted.

Questions with terms like "Exam Review", "Practice Test", and "Practice Exam" are not abusive and can be attempted.

# Honor Code: Dealing with

## – Third-Party Links

**Do not solve** questions containing external links.

-You must skip such questions under the “**This question violates authoring guidelines: > Copyright/External URL**” reason.

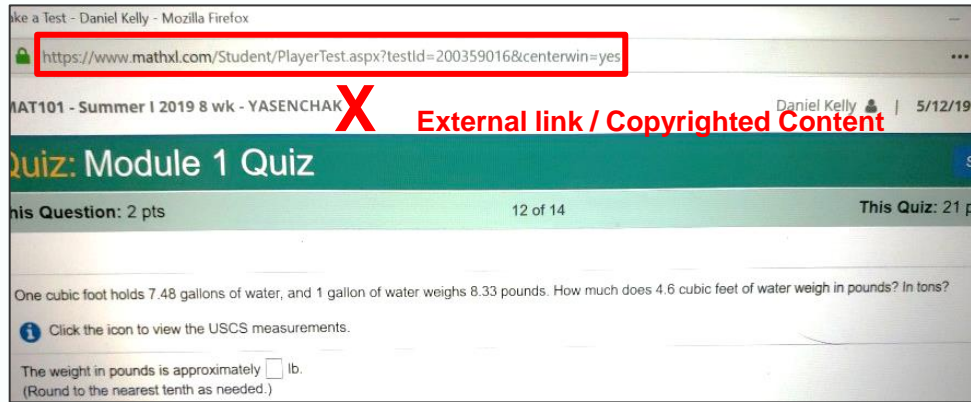

A screenshot of a web browser showing a quiz interface. The address bar contains the URL <https://www.mathxl.com/Student/PlayerTest.aspx?testId=200359016&centerwin=yes>, which is highlighted with a red box. Below the address bar, the page title is "MAT101 - Summer I 2019 8 wk - YASENCHAK" and the user is identified as "Daniel Kelly". A large red "X" is overlaid on the page with the text "External link / Copyrighted Content". The quiz title is "Quiz: Module 1 Quiz". The current question is "This Question: 2 pts" out of "12 of 14" questions, and the total quiz score is "This Quiz: 21 p". The question text is: "One cubic foot holds 7.48 gallons of water, and 1 gallon of water weighs 8.33 pounds. How much does 4.6 cubic feet of water weigh in pounds? In tons?" There is a note: "Click the icon to view the USCS measurements." and a text input field: "The weight in pounds is approximately  lb. (Round to the nearest tenth as needed.)"

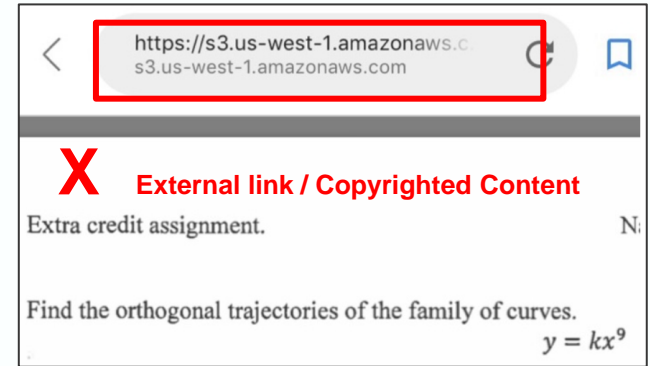

A screenshot of a mobile application interface. The address bar contains the URL <https://s3.us-west-1.amazonaws.com/s3.us-west-1.amazonaws.com>, which is highlighted with a red box. Below the address bar, a large red "X" is overlaid with the text "External link / Copyrighted Content". The text on the screen includes "Extra credit assignment." and "Find the orthogonal trajectories of the family of curves." followed by the equation  $y = kx^9$ .

# Honor Code: Dealing with

- Questions having points/marks/grades
- Opinion/ Perception-Based Questions, Essay Questions

## Do not solve :

- Questions that have points/marks/grades. Except for Questions having a tag  Safe to solve ⓘ
- You must skip all such questions under the **“This question violates authoring guidelines: > Points/Marks/Grades”** reason.

## Do not solve :

- Questions that explicitly ask for your opinion or personal input.
- Questions that explicitly ask for an essay or “essay writing”.
- You must skip all such questions under the **“This question violates authoring guidelines: > Spam”** reason.

Directions: Read and answer each question below carefully in not less than 5 sentences. (30 points)

1. If given the chance to design your own walking staff, what feature would you add to make it useful on the trail? (10 points) **X**
2. What are the safety tips you should consider when crossing a fast-flowing river? Provide at least 5 safety tips and briefly explain each. (10 points)
3. Which of the alternative rafts do you think is the safest when crossing a fast-flowing river? Explain your answer. (5 points)
4. Why is swimming important for survival? (5 points)

**Question**

Q1. Give your own example illustrating two of the following economic principles. **X**

- (a) How much is a decision at the margin.
- (b) People usually respond to incentives, exploiting opportunities to make themselves better off.

**Question**

**Essay Topic: X**

- What is corruption? How does it impact an economy?

Please make sure you mention your sources in the essay.

# Honor Code: Plagiarism

Copying content from any source, whether fully or partially, is considered plagiarism. At Chegg, we follow a **zero-tolerance policy** against plagiarism.

## **DO NOT:**

- Copy/paste solutions from any third-party sources.
- Copy/paste solutions from chegg.com.
- Copy/paste screenshots or photos of any work that isn't yours.
- Provide any links to external sources / websites / cloud as part of your solution.
- Quote parts of someone else's work even while giving them credit.

### **Note:**

If you have solved a similar question before, please take the time to review and revise your solution for every new question.

# Honor Code: Dealing with

## – Proctored Exam Questions

Proctored exams are timed, graded exams that a candidate takes on a computer while proctoring software identifies the candidate and supervises the candidate’s computer activity by capturing the computer screen, to ensure that the exam is being taken in accordance with the academic integrity rules of the university and professor.

**Do not solve** questions that contain images/terms from proctoring software, such as “Proctorio is sharing your screen”, “Honorlock is sharing your screen”, “Requires Respondus LockDown Browser”, or “ProctorU is sharing your screen”.

You must skip such questions under the **“This question violates authoring guidelines: > Spam”** reason.

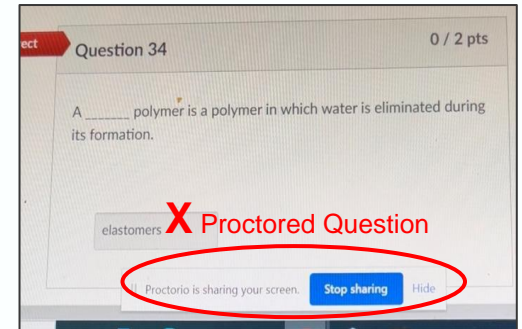
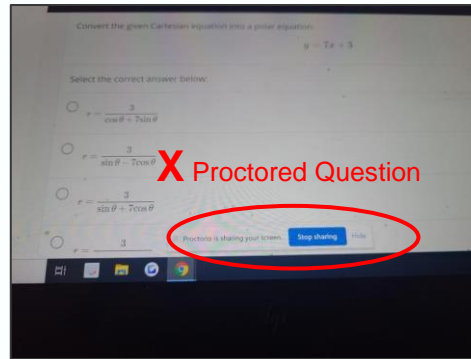
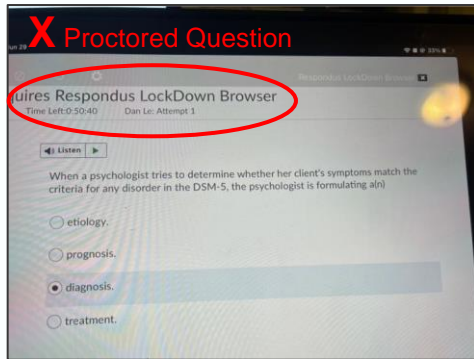

# Quality Review

Quality reviews are feedback given on your solutions by our quality team so that you can improve your overall authoring quality for students' better learning experience.

Your solutions are reviewed by our quality team mainly based on **5 parameters** namely **Accuracy, Concept, Explanation, Structure,** and **Authoring Guidelines.**

To check your Quality Reviews, go to the 'My solutions' tab.

You will find:

- **Chegg Rating** – Feedback shared by the Chegg Quality team.
- **Student Rating** – Feedback shared by the students.

The badge under 'Chegg Rating' indicates that your Quality Review for that solution is done.

- **Green** means “satisfactory”
- **Yellow** means “neutral”
- **Red** means “unsatisfactory”

Please note: You will **not be paid** for solutions that receive a “Red Badge” in the Quality Review

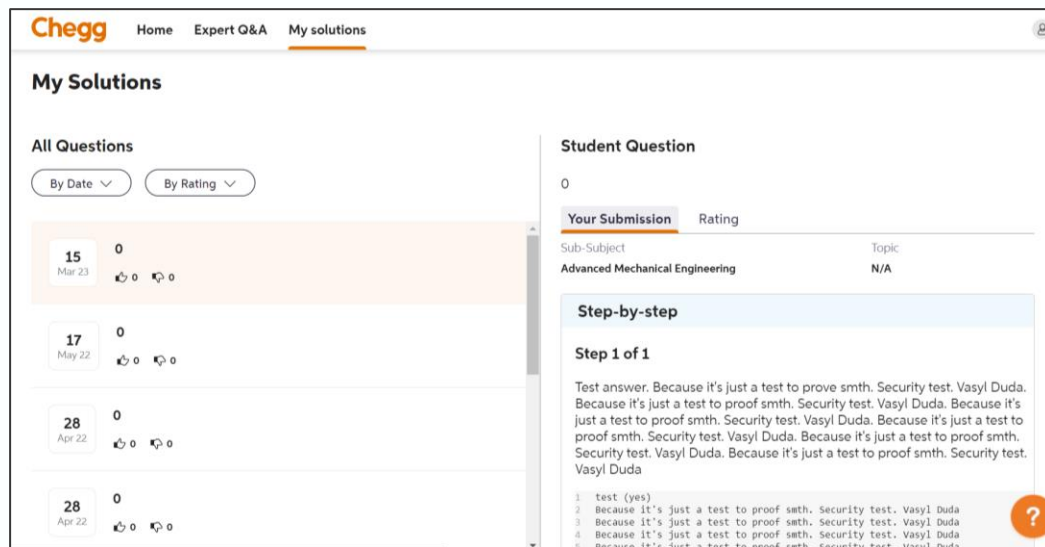

The screenshot shows the Chegg 'My Solutions' interface. At the top, there are navigation tabs for 'Home', 'Expert Q&A', and 'My solutions'. The main heading is 'My Solutions'. Below this, there are filters for 'All Questions' with options 'By Date' and 'By Rating'. A list of questions is displayed, each with a date badge (e.g., '15 Mar 23', '17 May 22', '28 Apr 22', '28 Apr 22') and a rating of '0'. To the right, a 'Student Question' panel is open, showing 'Your Submission' and 'Rating' tabs. The 'Your Submission' tab is active, displaying the question details: 'Sub-Subject: Advanced Mechanical Engineering' and 'Topic: N/A'. Below this, the 'Step-by-step' section shows 'Step 1 of 1' with a 'Test answer' and a list of numbered steps (1-5) for a security test. A red question mark icon is visible in the bottom right corner of the student question panel.

# Other Points to Keep in Mind

The following questions can be Attempted:

## Questions with

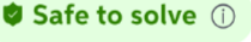
1. This tag:  Safe to solve ⓘ
2. Terms like Homework/Assignment/Experiment/Lab with or without points/marks from past academic periods/years
3. Terms like Exam Review/Quiz Review/Test Review
4. Terms like Graded assignment/assessment with past date
5. Logos of Laptops/Mobiles visible (like Dell, Apple, etc.)
6. CamScanner/any other image scanner Logo
7. Practice/Sample + Test/Quiz/Exam mentioned
8. "Spring"/"Fall" or "F" for any previous year
9. "Exam/Test/Quiz" from past academic periods/years
10. Terms like Practice assessments and assessments from study guides

The following questions should be marked under “ This question violates authoring guidelines: > (Correct Reason) ” :

## Questions with

1. Homework/Assignment/Experiment/Lab with points/marks/grades mentioned
2. Exam/Test/Quiz mentioned having current/future/no-academic periods/years.
3. Points/marks/grades mentioned having current/future/no-academic periods/years.
4. Graded assignment/assessment questions with due dates
5. External Website URL (even partially visible URL)
6. Company Name/Logo/Copyright/External Reference to book/website.
7. “Spring”/“Fall” or “F” with or without points/marks for the current/future/no-academic periods/years.
8. Take Home Exam/Take Home Test/Take Home Quiz with current /future dates.
9. Specific instructions to take “no outside help”.
10. Unethical intent. e.g., Questions requiring web scraping in the solution.

# Practices to Avoid

## Avoid prohibited behaviors, including these areas:

1. **Illegal:** Defamatory, libelous, copyright, privacy, patent, trademark, or contract rights violations
2. **Violent:** Abusive, harmful, harassing, threatening
3. **Inappropriate:** Sex, indecency, bodily function, obscenities, death/trauma/grief, socially offensive topics
4. **Prejudiced:** Bigotry, racism, xenophobia, sexism, ageist, disability, religious discrimination
5. **Malicious:** Security threats, exploitative
6. **Fraudulent:** Commercial activities, contests, sweepstakes, unsolicited advertising, spam
7. **Misappropriating:** Modifying, copying, distributing, downloading, scraping, or transmitting content

## Avoid:

1. Submitting solutions containing **AI-generated content**. Doing so would result in appropriate penalizations.
2. Asking students for feedback (**upvote/like/rating**) in the solutions
3. Use of **improper language/profanity** on Chegg Q&A platform
4. Sharing/asking for **personal details**
5. Skipping questions using **incorrect skip reason**
6. **Blaming/arguing** with student
7. Submitting **incomplete/incorrect/direct** solutions
8. Posting **irrelevant comments/suggestions**
9. Intentionally distributing the **wrong** solution
10. Submitting hard to read or **illegible solutions**
11. **Posting offsite requests** - All interactions between students and experts must occur via Q&A platform. If students are requesting offsite help, please flag this behavior as abusive/spam
12. Pasting **questions in the solution window**
13. Solving **blank questions**
14. Solving **incomplete questions**



# Payments

Payment for solutions submitted on Live Q&A during a month is **processed on the 15<sup>th</sup> day of the following month**.

## Terms of our payment policy:

- You are paid only for correct solutions that conform to Q&A solution guidelines.
- You must submit your **OWN** bank details (jointly-held bank accounts are prohibited).
- In line with Income Tax guidelines, Chegg is required to deduct applicable TDS on all payments made to Experts who have submitted their PAN card details. In such a case, you will be provided with a Form-16A mentioning the deduction.
- If payment is not processed in a particular month due to missing/incorrect bank details, they will be processed in next month's payment cycle only if the required details are provided in time.
- Any misuse of authoring privileges will lead to immediate account revocation and forfeiture of any due payments.

# How to Contact Us?

In case of any query, feel free to contact us through any of the following modes:

- Visit our **self-help** section at <https://qnasupport.cheggindia.com/portal/en/kb/expert-support>
- Submit a **support ticket** at <https://qnasupport.cheggindia.com/portal/en/newticket>

# Thank You